

## HY 8334.1

尼龙万向型垫脚  
Levelling feet Nylon base,  
Universal type

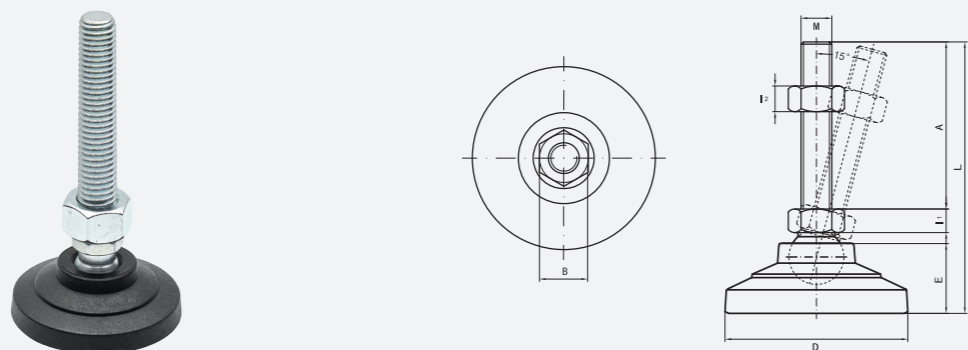

型号 Type	材料 Material		表面处理 Surfaced process	
	螺杆	底座	螺杆	底座
HY8334.1	Q235	增强尼龙	镀锌	黑色
HY8334.1S	SUS304	增强尼龙	本色	抛光

订货示例: Type \ D - M x A  
例如钢制: HY8334.1\60-M16x100  
例如不锈钢制: HY8334.1S\60-M16x100

参数尺寸 Parameter Size

型号 Type	主要尺寸 Main dimensions								垂直负载 (kN)	
	D	M	A	L	L1	L2	E	B		
HY8334.1 HY8334.1S	40	10	80	105	6	8	17	17	1.0	
			100	125						
		12	127	8	10	19				
			150					177		
	50	10	80	105	6	8	17.5	17		
			100	125						
		12	127	8	10	19				
			150					177		
		16	100	129	10	12		24		
			120	149						
	60	10	80	112	6	8	22	17		1.5
			100	132						
12		134	8	10	19					
		120				154				
16		100	136	10	12	24				
		120	156							
		150	186							
		120	158							
20	150	188	12	16	30					
	150	188								
	200	238								
	200	238								

## HY 8334.2

带胶防滑尼龙万向型垫脚  
Levelling feet Nylon base with anti-slip  
rubber pad, Universal type



型号 Type	材料 Material			表面处理 Surfaced process	
	螺杆	底座	胶部	螺杆	底座
HY8334.2	Q235	增强尼龙	橡胶	镀锌	黑色
HY8334.2S	SUS304	增强尼龙	橡胶	本色	抛光

订货示例: Type \ D - M x A  
例如钢制: HY8334.2\60-M16x100  
例如不锈钢制: HY8334.2S\60-M16x100

参数尺寸 Parameter Size

型式 Type	主要尺寸 Main dimensions								垂直负载 (kN)
	D	M	A	L	L1	L2	E	B	
HY8334.2 HY8334.2S	40	10	80	108	6	8	20	17	1.0
			100	128					
		12	130	8	10	19			
			150					180	
	50	10	80	108	6	8	20.5	17	
			100	128					
		12	130	8	10	19			
			150					180	
		16	100	132	10	12		24	
			120	152					
	60	10	80	115	6	8	25	17	
			100	135					
12		136	8	10	19				
		120				156			
16		100	138	10	12	24			
		120	158						
		150	188						
		120	160						
20	150	190	12	16	30				
	150	190							
	200	240							
	200	240							

垫脚

垫脚

Levelling Mount

Levelling Mount

## HY 8334.3

### 防滑尼龙万向型垫脚

Levelling feet Nylon base with anti-slip rubber pad, Universal type

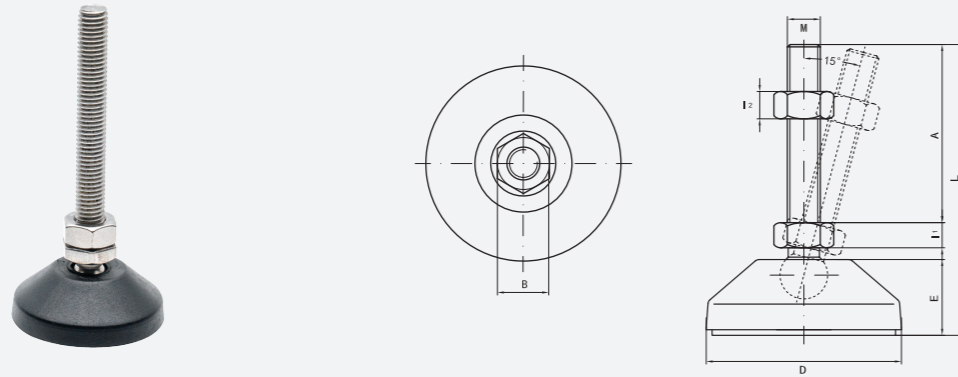

材料 Material			表面处理 Surfaced process
螺杆	底座	胶部	螺杆
Q235	尼龙	橡胶	镀锌

订货示例: Type \ D - M x A  
 例如钢制: HY8334.3\60-M16x100

参数尺寸 Parameter Size

型号 Type	主要尺寸 Main dimensions								垂直负载 (kN)
	D	M	A	L	L1	L2	E	B	
HY 8334.3	50	8	50	78	5	5.5	20	13	1.2
			80	108					
		10	100	129.5	6.5	8			
			150	180					
		12	100	130.5	7.5	9		18	
			150	180.5					
	100		134.5						
	150		184.5						
	60	16	100	136	9	12	24	24	1.5
			150	186					
		20	100	138	11	14		30	
			150	188					
	70	12	100	134.5	7.5	9	24	18	3
			150	184.5					
		16	100	136	9	12		24	
			150	186					
20		100	138	11	14	30			
		150	188						
100	12	120	135.5	7.5	9	25	18	6	
		150	185.5						
	16	200	137	9	12		24		
		100	187						
	20	150	139	11	14		30		
		200	189						

## HY 8334.4

### 带胶防滑型垫脚

Levelling feet Metal base with anti-slip rubber pad, Fixed type

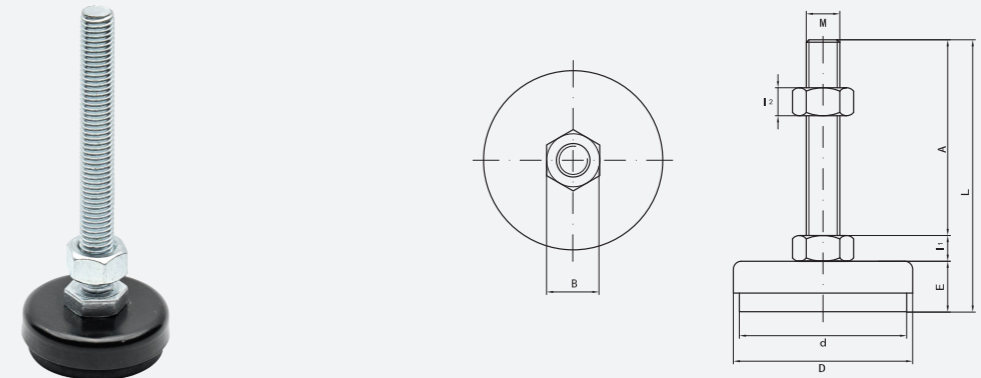

型号 Type	材料 Material			表面处理 Surfaced process	
	螺杆	底座	胶部	螺杆	底座
HY8334.4	Q235	Q235	橡胶	镀锌	电泳黑
HY8334.4S	SUS304	SUS304	橡胶	本色	电解抛光

订货示例: Type \ D - M x A  
 例如钢制: HY8334.4\50-M12x80  
 例如不锈钢制: HY8334.4S\50-M12x80

参数尺寸 Parameter Size

型号 Type	主要尺寸 Main dimensions									垂直负载 (kN)
	D	M	A	L	L1	L2	E	B	d	
HY8334.4 HY8334.4S	40	8	60	82.5	5.5	6.5	17	13	35.5	3
			80	104						
	50	12	100	125	8	10		19	45.5	4
			100	127						
	60	16	100	130	10	13		24	55.5	4.5
			150	177						
		20	100	130	13	16	30			
			120	150						
	80	16	100	129	10	13	24	75.5	4.5	
			120	149						
		20	150	179	13	16				30
			120	152						
		24	150	184	15	19				36
			180	214						
	100	20	120	152	13	16	30	95.5	4.5	
			150	182						
24		150	184	15	19	36				
		180	214							

## HY 8334.5

### 防震橡胶型脚垫

Levelling feet Vibration-proof rubber base, Fixed type

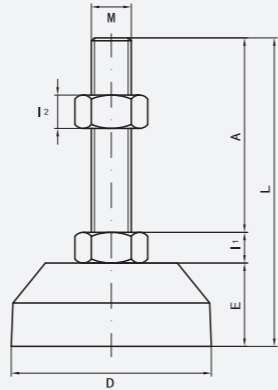
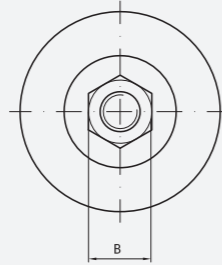

螺杆		底座
材料	表面处理	材料
Q235	镀锌	橡胶

订货示例: Type \ D - M x A  
 例如: HY8334.5\60-M12x100

参数尺寸 Parameter Size

型号 Type	主要尺寸 Main dimensions									垂直负载 (kN)
	D	M	A	L	L1	L2	E	B	H	
HY 8334.5	60	12	100	133	8	10	25	19	13	1
			120	153						
		16	100	135	10	13		24		
			120	155						
	70	16	150	185	10	13	29	14	2	
			100	139						
		20	120	159			32			17.5
			150	189						
	100	20	150	195	13	16	35	30	17	3.5
			200	245						
		24	120	168	15	19	35	36	17	4
			150	198						
		200	248							
		150	200							
	180	230								
	200	250								

## HY 8334.6

### 金属万向型垫脚

Levelling feet Metal base, Universal type

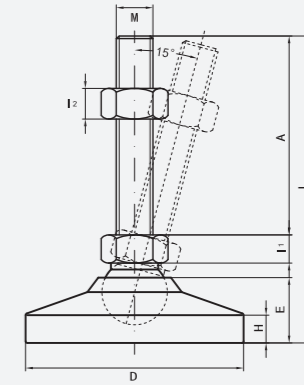
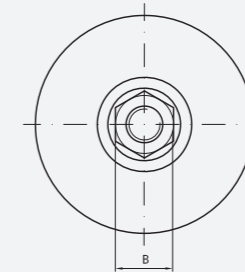

型号 Type	材料 Material		表面处理 Surfaced process	
	螺杆	底座	螺杆	底座
HY8334.6	Q235	Q235	镀锌	镀锌
HY8334.6S	SUS304	SUS304	本色	抛光

订货示例: Type \ D - M x A  
 例如钢制: HY8334.6\80-M16x150  
 例如不锈钢制: HY8334.6S\80-M16x150

参数尺寸 Parameter Size

型号 Type	主要尺寸 Main dimensions									垂直负载 (kN)	
	D	M	A	L	L1	L2	E	B	H		
HY8334.6 HY8334.6S	65	12	100	131.5	8	10	18	19	8	4	
			150	181.5							
		16	100	133.5	10	13		24			
			150	183.5							
	80	16	100	135.5	10	13	20	24	9	10	
			150	185.5							
		20	100	138.5				13		16	30
			150	188.5							
			180	218.5							
	100	20	120	141	13	16	22	30	10	20	
			150	191							
		24	180	221	14	19	36				
100			142								
			150	192							
			180	222							

## HY 8334.7

### 防滑万向型脚垫

Levelling feet Metal base with anti-slip rubber pad, Universal type

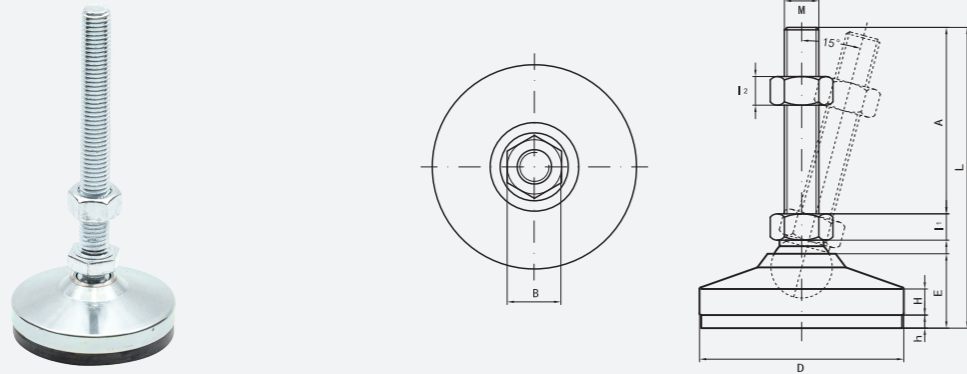

型号 Type	材料 Material			表面处理 Surfaced process	
	螺杆	底座	胶部	螺杆	底座
HY8334.7	Q235	Q235	橡胶	镀锌	镀锌
HY8334.7S	SUS304	SUS304	橡胶	本色	抛光

订货示例: Type \ D - M x A  
例如钢制: HY8334.7\80-M16x150  
例如不锈钢制: HY8334.7S\80-M16x150

参数尺寸 Parameter Size

型号 Type	主要尺寸 Main dimensions										垂直负载 (kN)			
	D	M	A	L	L1	L2	E	B	H	h				
HY8334.7 HY8334.7S	65	12	100	137	8	10	24	19	8	6	4			
			150	187										
		16	100	139	10	13		24	4					
			150	189										
		80	16	100	141	10		13	26	24		9	6	10
				150	191									
	20		100	144	13	16	30	14						
			150	194										
	100	20	120	148	13	16	29	30	10	7	20			
			150	198										
			200	248										
		24	100	150	14	19		36			25			
150			200											
200			250											

## HY 8334.8

### 重载型垫脚

Levelling feet Metal base, Heavy load type

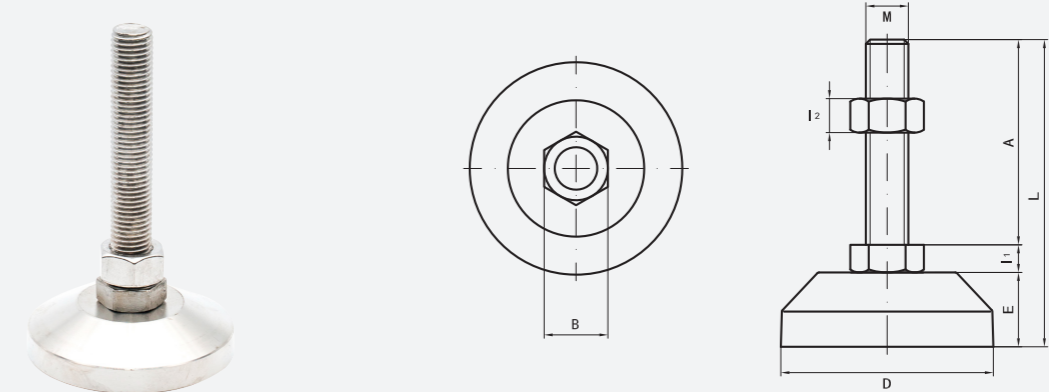

型号 Type	材料 Material		表面处理 Surfaced process	
	螺杆	底座	螺杆	底座
HY8334.8	Q235	Q235	镀锌	镀锌
HY8334.8S	SUS304	SUS304	本色	本色

订货示例: Type \ D - M x A  
例如钢制: HY8334.8\50-M10x80  
例如不锈钢制: HY8334.8S\50-M10x80

参数尺寸 Parameter Size

型号 Type	主要尺寸 Main dimensions								垂直负载 (kN)
	D	M	A	L	L1	L2	E	B	
HY8334.8 HY8334.8S	50	8	50	76.5	5.5	6.5	21	13	4
			80	106.5					
	60	10	100	109	7	8	22	17	5
			80	110					
		12	100	130	8	10		19	6
			150	180					
		16	100	132	10	13		24	7
			120	152					
			150	182					
			100	135					
		20	120	155	13	16		30	8
			150	185					
	200		235						
	100		132						
	80	16	120	152	10	13	22	24	7
			150	180					
		20	120	155	13	16		30	8
			150	185					
			200	235					
			150	187					
	24	180	217	15	19	36	10		
		200	237						
		120	154						
		150	184						
100	20	150	184	13	16	21.5	30	9	
		200	234						
	24	150	186	15	19		36	10	
		180	216						
		200	236						
		150	186						

## HY 8334.9

### 重载防滑型脚垫

Levelling feet Metal base with anti-slip rubber pad, Heavy load type

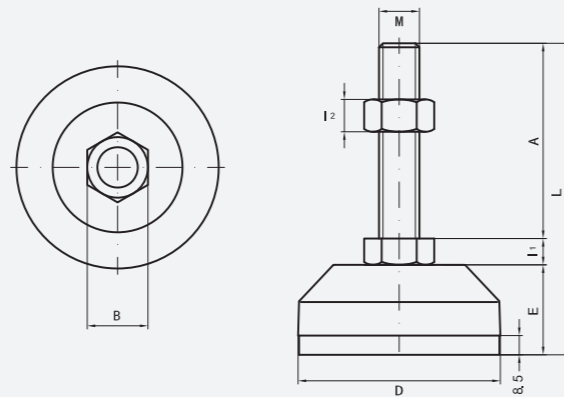

型号 Type	材料 Material			表面处理 Surfaced process	
	螺杆	底座	胶部	螺杆	底座
HY8334.9	Q235	Q235	橡胶	镀锌	镀锌
HY8334.9S	SUS304	SUS304	橡胶	本色	本色

订货示例: Type \ D - M x A  
 例如钢制: HY8334.9\60-M10x100  
 例如不锈钢制: HY8334.9S\60-M10x100

参数尺寸 Parameter Size

型号 Type	主要尺寸 Main dimensions								垂直负载 (kN)
	D	M	A	L	L1	L2	E	B	
HY8334.9 HY8334.9S	50	8	50	84.5	5.5	6.5	21	13	4
			80	114.5					
	60	10	100	116	7	8	22	17	5
			80	136					
		12	100	117	8	10		19	6
			100	137					
			120	157					
			100	139					
			120	159					
			150	189					
		16	120	159	10	13		24	7
			150	189					
	120		162						
	150		189						
	20	150	192	13	16	30	8		
		200	242						
		100	140						
		120	160						
150		190							
120		163							
80	20	150	193	13	16	22	30	8	
		200	243						
	24	150	195	15	19		36	10	
		180	225						
		200	245						
		120	163						
100	20	150	193	13	16	21.5	30	9	
		200	243						
	24	150	195	15	19		36	10	
		180	225						
		200	245						
		120	163						

## HY 8334.10

### 尼龙固定型垫脚

Levelling feet Nylon base, Fixed type

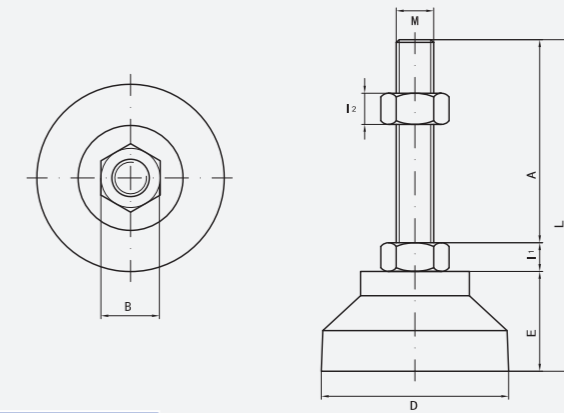

型号 Type	材料 Material		表面处理 Surfaced process
	螺杆	底座	螺杆
HY8334.10	Q235	尼龙	镀锌
HY8334.10S	SUS304	尼龙	本色

订货示例: Type \ D - M x A  
 例如钢制: HY8334.10\60-M10x100  
 例如不锈钢制: HY8334.10S\60-M10x100

参数尺寸 Parameter Size

型号 Type	主要尺寸 Main dimensions								垂直负载 (kN)
	D	M	A	L	L1	L2	E	B	
HY8334.10 HY8334.10S	50	8	50	84.5	5.5	6.5	24	13	1.8
			80	114.5					
	60	10	100	116	7	8	29	17	2.1
			80	136					
		12	100	117	8	10		19	
			100	137					
			120	157					
			100	139					
			120	159					
			150	189					
		16	120	159	10	13		24	
			150	189					
	120		162						
	150		189						
	20	150	192	13	16	30			
		200	242						
		100	140						
		120	160						
150		190							
120		163							
80	20	150	193	13	16	25	30	2.5	
		200	243						
	24	150	195	15	19		36		
		180	225						
		200	245						
		120	163						
100	20	150	193	13	16	27	30	2.1	
		200	243						
	24	150	195	15	19		36		
		180	225						
		200	245						
		120	163						

## HY 8334.11

黄胶型垫脚  
Levelling feet Steel base,  
Yellow PVC type

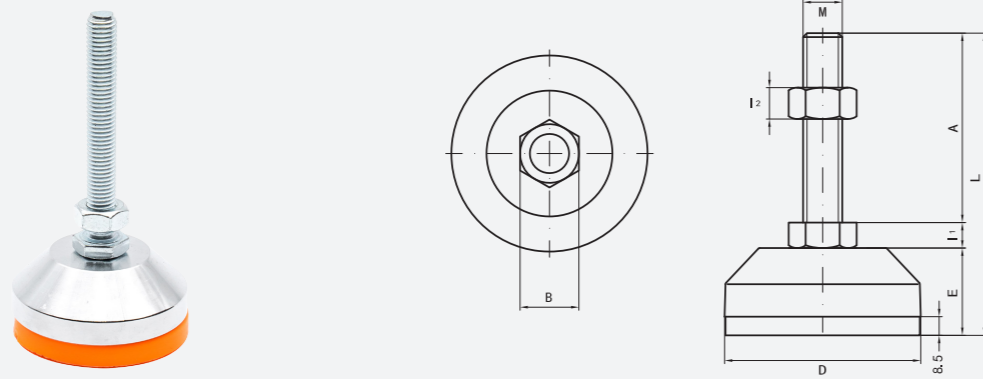

材料 Material			表面处理 Surfaced process	
螺杆	底座	胶部	螺杆	底座
Q235	Q235	PVC	镀锌	镀铬

订货示例: Type \ D - M x A  
例如: HY8334.11\60-M12x100

参数尺寸 Parameter Size

型号 Type	主要尺寸 Main dimensions								垂直负载 (kN)					
	D	M	A	L	L1	L2	E	B						
HY 8334.11	50	8	50	90	5.5	6.5	28	13	4					
			80	120										
	60	10	100	117	7	8	30	17	5					
			137											
		12	120	138	8	10	30	19	6					
			158											
		16	100	140	10	13	30	24	7					
			120	160										
			150	190										
			120	163										
	20	150	193	13	16	30	30	8						
		200	243											
		16	100						149.5	10	13	30	24	7
			120						169.5					
			150						199.5					
		80	20						120	172.5	13	16	31	30
150	202.5													
200	252.5													
24	150		204.5	15	19	31	36	10						
	180		234.5											
	200		254.5											

## HY 8334.12

黄胶带孔型垫脚  
Levelling feet Steel base with mounting holes,  
Yellow PVC type

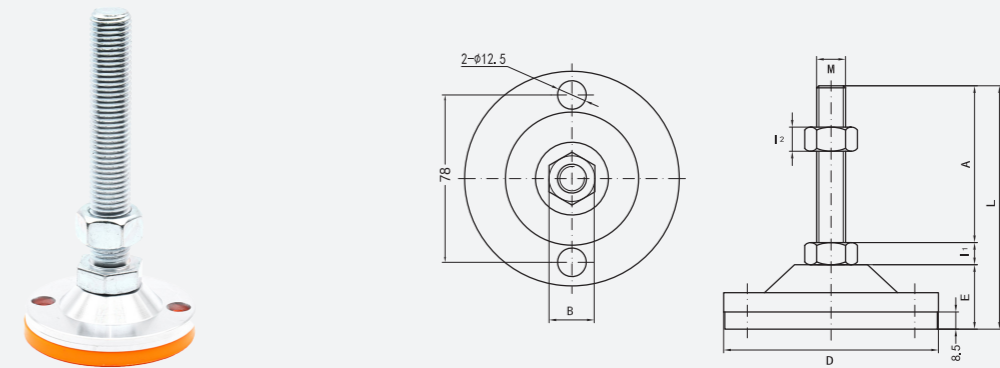

材料 Material			表面处理 Surfaced process	
螺杆	底座	胶部	螺杆	底座
Q235	Q235	PVC	镀锌	镀铬

订货示例: Type \ D - M x A  
例如: HY8334.12\100-M12x100

参数尺寸 Parameter Size

型号 Type	主要尺寸 Main dimensions								垂直负载 (kN)						
	D	M	A	L	L1	L2	E	B							
HY 8334.12	100	12	100	138	8	10	30	19	7						
			120	158											
		16	100	140	10	13	30	24	8						
			120	160											
			150	190											
		20	120	163	13	16	30	30	9						
			150	193											
			200	243											
			24	150						195	15	19	30	36	10
				180						225					
200	245														



## HY 8334.13

平底标准型垫脚  
Levelling feet Metal base,  
Flat bottom standard type

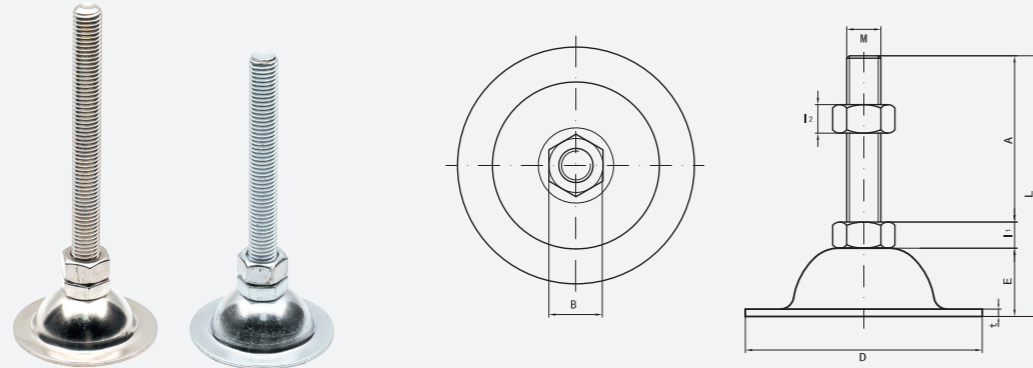

型号 Type	材料 Material		表面处理 Surfaced process	
	螺杆	底座	螺杆	底座
HY8334.12	Q235	Q235	镀锌	镀锌
HY8334.12S	SUS304	SUS304	本色	电解抛光

订货示例: Type \ D - M x A  
例如钢制: HY8334.13\60-M12x80  
例如不锈钢制: HY8334.13S\60-M12x80

参数尺寸 Parameter Size

型号 Type	主要尺寸 Main dimensions									垂直负载 (kN)
	D	M	A	L	L1	L2	E	B	t	
HY 8334.12 HY 8334.12S	38	10	80	99.5	7	8	12.5	17	1.6	4
			100	119.5						
	60	12	120	128	8	10	20	19	2	
			120	148						
	75	16	100	132	10	13	22	24	2	
			120	152						
			150	182						
		24	120	155	13	16	22	30	2	
			150	185						
			200	235						

## HY 8334.14

带胶平底型垫脚  
Levelling feet Metal base with rubber pad,  
Flat bottom type

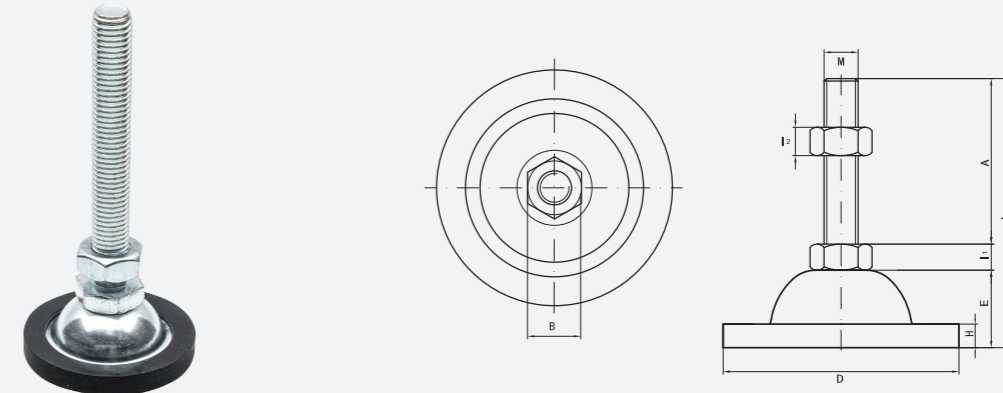

型号 Type	材料 Material			表面处理 Surfaced process	
	螺杆	底座	胶部	螺杆	底座
HY8334.14	Q235	Q235	橡胶	镀锌	镀锌
HY8334.14S	SUS304	SUS304	橡胶	本色	电解抛光

订货示例: Type \ D - M x A  
例如钢制: HY8334.14\70-M12x80  
例如不锈钢制: HY8334.14S\70-M12x80

参数尺寸 Parameter Size

型号 Type	主要尺寸 Main dimensions									垂直负载 (kN)
	D	M	A	L	L1	L2	E	B	H	
HY 8334.14 HY 8334.14S	45	8	60	81	5.5	6.5	15.5	13	6	2.07
			80	102.5	7	8		17		2.25
		100	122.5	7	8	17		2.34		
	70	12	80	111	8	10	23	19	7	3.51
			100	131						3.69
			120	151						3.87
	80	16	100	135	10	13	25	24	8	4.59
			120	155						4.86
			150	185						5.04
		20	150	238	13	16	25	30	8	6.66
			200	235						7.65

## HY 8334.15

### 偏心固定型垫脚

Levelling feet Metal base with mounting holes, Eccentric fixed type

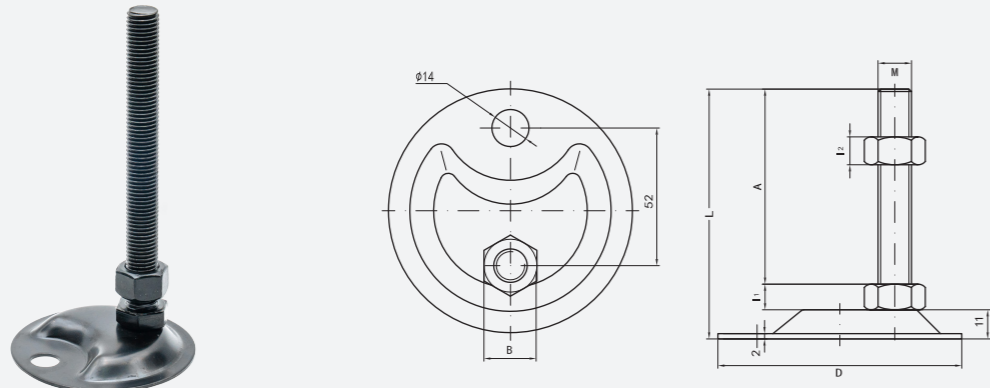

型号 Type	材料 Material		表面处理 Surfaced process	
	螺杆	底座	螺杆	底座
HY8334.15	Q235	Q235	镀锌	镀锌
HY8334.15Y	Q235	Q235	镀锌	电泳黑
HY8334.15S	SUS304	SUS304	本色	抛光

订货示例: Type \ D - M x A  
例如钢制镀锌: HY8334.15\90-M16x100  
例如钢制电泳: HY8334.15Y\90-M16x100  
例如不锈钢制: HY8334.15S\90-M16x100

参数尺寸 Parameter Size

型号 Type	主要尺寸 Main dimensions							垂直负载 (kN)	
	D	M	A	L	L1	L2	B		
HY 8334.15 HY 8334.15Y HY 8334.15S	90	12	50	69	8	10	19	1.2	
			100	119					
		16	50	71	10	13	24		1.4
			100	121					
			150	171					

## HY 8334.16

### 水滴固定型垫脚

Levelling feet Metal base with mounting holes, Water drop fixed type

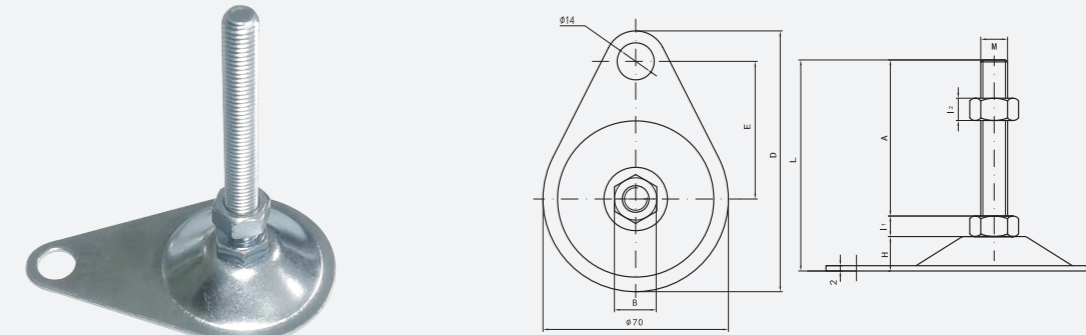

型号 Type	材料 Material		表面处理 Surfaced process	
	螺杆	底座	螺杆	底座
HY8334.16	Q235	Q235	镀锌	镀锌
HY8334.16Y	Q235	Q235	镀锌	电泳黑
HY8334.16S	SUS304	SUS304	本色	抛光

订货示例: Type \ D - M x A  
例如钢制镀锌: HY8334.16\98.5-M16x100  
例如钢制电泳: HY8334.16Y\98.5-M16x100  
例如不锈钢制: HY8334.16S\98.5-M16x100

参数尺寸 Parameter Size

型号 Type	主要尺寸 Main dimensions									垂直负载 (kN)
	D	M	A	L	L1	L2	B	E	H	
HY 8334.16 HY 8334.16Y HY 8334.16S	98.5	10	80	100	7	8	17	52	14	2.0
			100	120						
		12	50	71	8	10	19			
			100	121						
		16	150	171	10	13	24			
			50	73						
	115.5	10	80	100	7	8	17	69	14	2.0
			100	121						
		12	50	72	8	10	19			
			100	122						
		16	150	172	10	13	24			
			50	74						
		100	124							
		150	174							



# HY 8334.17

带孔定位型垫脚  
Levelling feet Steel base with mounting holes, Positioning type

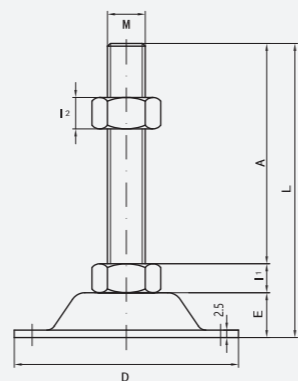
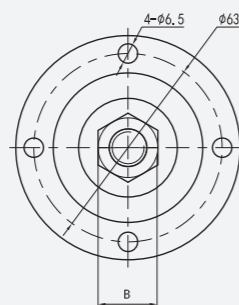

材料 Material		表面处理 Surfaced process	
螺杆	底座	螺杆	底座
Q235	Q235	镀锌	镀铬

订货示例: Type \ D - M x A  
例如: HY8334.17\75-M12x100

参数尺寸 Parameter Size

型号 Type	主要尺寸 Main dimensions								垂直负载 (kN)	
	D	M	A	L	L1	L2	B	E		
HY 8334.17	75	12	50	73	8	10	19	15	3	
			100	123						
			150	173						
		16	50	75	10	13	24			4
			100	125						
			150	175						
	20	100	128	13	16	30	7			
		150	178							

# na COUPLING 联轴器

- 小型十字万向联轴节  
Universal Joints
- 十字顶丝型联轴器  
Set screw type oldham coupling
- 三节万向联轴节  
Universal Joints
- 单膜片顶丝型联轴器  
Single set screw type disc coupling
- 弹性联轴节  
Flexible couplings
- 单膜片夹紧型联轴器  
Single clamping type disc coupling
- 夹紧式弹性联轴节  
Clamping-type flexible couplings
- 双膜片夹紧型联轴器  
Double clamping type disc coupling
- 沟槽式夹紧型联轴器  
Clamping type slit coupling
- 双膜片顶丝型联轴器  
Double set screw type disc coupling
- 沟槽式顶丝型联轴器  
Set screw type slit coupling
- 爪形夹紧型弹性联轴器  
Claw shaped top thread elastic coupling
- 十字夹持型联轴器  
Clamping type oldham coupling
- 爪形顶丝型弹性联轴器  
Set screw type jaw coupling